

## GAD-501 Levelling Glide

### Features

- Special surface finishes and dimensions also available on made-to-order basis
- Height adjustable on cross-recessed (M8) or slotted (M10) top of threaded bolt with screwdriver
- Cover installed at the bottom to prevent scratching of floor available

Top of threaded bolt  
(See below table for types)

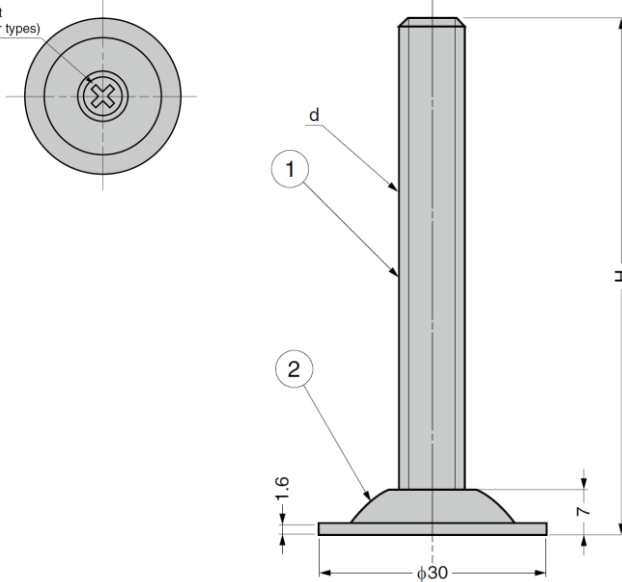

No.	Part Name	Material	Finish
①	Shaft	Steel (SWCH)	Coloured Zinc Chromate
②	Base	See Below	(Trivalent)

Part No.	Base Material	d	Bolt Top / Type	H	Load Capacity (per piece)	
GAD-501-30E	Steel (SPCC)	M8	Cross Recess	30	980 N	100 kg
GAD-501-50E	Steel (SPHC)			50		
GAD-501-60E	Steel (SPCC)			60		
GAD-501-70E	Steel (SPHC)			70		
GAD-501-75E				75		
GAD-501-80E				80		
GAD-501-90E	Steel (SPCC)			90		
GAD-501-105E	Steel (SPHC)			105		
GAD-501-120E				120		
GAD-501-130E				130		
GAD-501-30G	Steel (SPCC)	M10	Slot	30	1,372 N	140 kg
GAD-501-60G				60		
GAD-501-90G				90		
GAD-501-120G				120		